

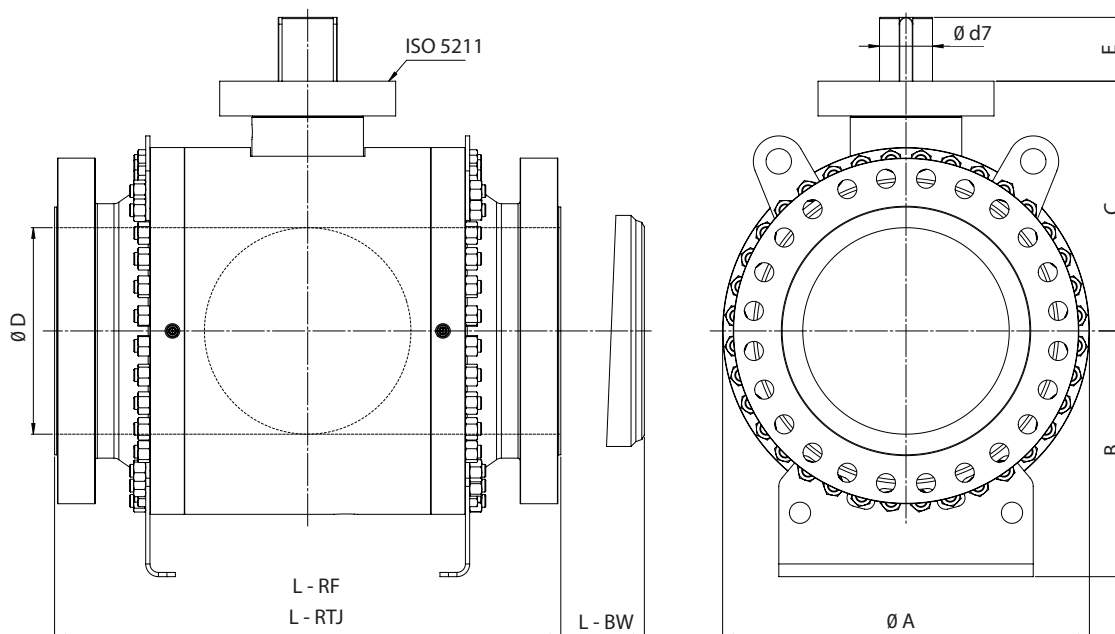

NPS 2"-56" • Class 150-2500 • DN 50-1400 • PN 16-400  
 Tmax 220 °C  
 Design: SPLIT BODY

Connection: ☉ ASME B16.5, EN 1092-1 FLANGED ENDS  
 ☉ ASME B16.25, EN 12 627 WELDED ENDS



If another face to face dimension is required, which is not stated in the charts then it is agreed mutually.  
 B and C dimensions are informative only, final dimensions based on requested accessories.

## Class 150 • PN 16-25

NPS / DN	Dimensions [mm]									ISO 5211	° kg	
	ØD	L <sub>RF</sub>	L <sub>BW</sub>	L <sub>RTJ</sub>	ØA	B	C	E	Ød <sub>7</sub>		RF	BW
2" / 50	49	178	216	191	185	112	127	35	27	F10	27	21
3" / 80	74	203	283	216	220	130	146	50	36	F12	46	41
4" / 100	100	229	305	241	255	198	200	48	38	F12	70	58
6" / 150	150	394	457	406	326	248	252	64	48	F14	154	185
8" / 200	201	457	521	470	405	280	294	64	48	F14	264	323
10" / 250	252	533	559	546	480	340	350	77	58	F16	420	510
12" / 300	303	610	635	622	565	385	391	73	58	F16	695	771
14" / 350	334	686	762	699	620	425	425	90	75	F25	900	992
16" / 400	385	762	838	775	695	470	465	90	75	F25	1230	1362
18" / 450	438	864	914	876	760	477	498	90	75	F30	1940	1909
20" / 500	487	914	991	927	865	580	567	126	98	F30	2227	2326
24" / 600	589	1067	1143	1080	1020	650	650	110	98	F30	3080	3833
28" / 700	684	1245	1346	-	1180	680	749	180	125	F35	4556	5130
30" / 750	737	1295	1397	-	1240	758	739	185	130	F40	5325	6225
32" / 800	781	1372	1524	-	1325	768	791	240	150	F40	6614	7912
34" / 850	832	1473	1626	-	1405	793	827	200	150	F40	8910	8935
36" / 900	876	1524	1727	-	1468	834	849	245	150	F48	9980	9908
40" / 1000	978	1625	1780	-	1610	945	967	245	200	F40	10674	12535
42" / 1050	1022	1700	1800	-	1690	965	1012	245	170	F40	14500	14715
48" / 1200	1166	2060	2000	-	1900	1160	1140	245	170	F48	17900	16750
56" / 1400	1360	2160	2250	-	2190	1280	1278	245	180	F48	23620	22442



NPS 2"-56" • Class 150-2500 • DN 50-1400 • PN 16-400  
 Tmax 220 °C  
 Design: SPLIT BODY

Connection: ☉ ASME B16.5, EN 1092-1 FLANGED ENDS  
 ☼ ASME B16.25, EN 12 627 WELDED ENDS

### Class 300 • PN 40

NPS / DN	Dimensions [mm]									ISO 5211	° kg	
	øD	L <sub>RF</sub>	L <sub>BW</sub>	L <sub>RTJ</sub>	øA	B	C	E	ød <sub>r</sub>		RF	BW
2" / 50	49	216	216	232	185	112	127	35	27	F10	28	22
3" / 80	74	283	283	298	238	119	180	50	36	F12	62	66
4" / 100	100	305	305	321	248	125	188	50	38	F12	80	90
6" / 150	150	403	457	419	326	248	252	64	48	F14	172	185
8" / 200	201	502	521	518	416	280	294	64	48	F14	287	323
10" / 250	252	568	559	584	480	340	350	77	58	F16	457	510
12" / 300	303	648	635	664	565	385	391	73	58	F16	706	771
14" / 350	334	762	762	778	620	425	425	90	75	F25	988	992
16" / 400	385	838	838	854	690	470	465	90	75	F25	1366	1362
18" / 450	438	914	914	930	780	477	498	126	98	F30	1890	1909
20" / 500	487	991	991	1010	865	580	567	120	98	F30	2333	2326
24" / 600	589	1143	1143	1165	1020	650	621	110	98	F30	3406	3833
28" / 700	684	1346	1346	1372	1130	680	749	151	125	F35	4460	5130
30" / 750	737	1397	1397	1426	1240	758	739	185	130	F40	5325	6225
32" / 800	781	1524	1524	1553	1325	768	791	185	130	F40	6614	7912
34" / 850	832	1626	1626	1654	1405	793	827	197	150	F40	8910	8935
36" / 900	876	1727	1727	1756	1468	834	849	225	150	F48	9980	9908
40" / 1000	978	1850	2000	-	1620	945	960	200	150	F40	12219	12535
42" / 1050	1022	1900	2100	-	1690	965	1012	245	170	F40	14500	14715
48" / 1200	1166	2180	2100	-	1900	1160	1140	245	170	F48	17900	16750
56" / 1400	1360	2300	2250	-	2190	1280	1278	245	180	F48	23620	22442

### Class 400-600 • PN 63-100

NPS / DN	Dimensions [mm]									ISO 5211	° kg	
	øD	L <sub>RF</sub>	L <sub>BW</sub>	L <sub>RTJ</sub>	øA	B	C	E	ød <sub>r</sub>		RF	BW
2" / 50	49	292	292	295	185	112	129	35	27	F10	33	28
3" / 80	74	356	356	359	238	119	180	50	36	F12	69	66
4" / 100	100	432	432	435	265	132	188	50	38	F12	113	92
6" / 150	150	559	559	562	340	250	259	64	48	F14	248	197
8" / 200	201	660	660	664	425	302	321	75	58	F16	445	340
10" / 250	252	787	787	791	500	376	362	90	75	F25	702	545
12" / 300	303	838	838	841	580	420	404	90	75	F25	965	791
14" / 350	334	889	889	892	630	445	449	120	98	F30	1207	1074
16" / 400	385	991	991	994	705	487	489	120	98	F30	1620	1463
18" / 450	438	1092	1092	1095	780	477	498	126	98	F30	2038	1998
20" / 500	487	1194	1194	1200	865	580	589	151	125	F35	2909	2411
24" / 600	589	1397	1397	1407	1030	620	672	151	125	F35	4154	3976
28" / 700	684	1549	1549	1562	1150	680	717	185	125	F40	5700	5330
30" / 750	737	1651	1651	1664	1265	733	792	185	130	F40	6990	6450
32" / 800	781	1778	1778	1794	1365	783	815	245	150	F40	9040	8183
34" / 850	832	1930	1930	1946	1460	830	863	245	150	F48	10924	9450
36" / 900	876	2083	2083	2099	1510	905	892	225	150	F48	12183	10376
40" / 1000	978	2000	2000	-	1650	970	995	235	180	F48	14132	12910
42" / 1050	1022	2100	2100	-	1725	982	1013	265	180	F48	16975	15230
48" / 1200	1166	2400	2200	-	1930	1180	1148	265	180	F48	21180	19895
56" / 1400	1360	2540	2350	-	2240	1280	1318	241	200	F60	27320	25807



NPS 2"-56" • Class 150-2500 • DN 50-1400 • PN 16-400  
 Tmax 220 °C  
 Design: SPLIT BODY

Connection: ☉ ASME B16.5, EN 1092-1 FLANGED ENDS  
 ☼ ASME B16.25, EN 12 627 WELDED ENDS

## Class 900 • PN 160

NPS / DN	Dimensions [mm]									ISO 5211	° kg	
	øD	L <sub>RF</sub>	L <sub>BW</sub>	L <sub>RTJ</sub>	øA	B	C	E	ød <sub>7</sub>		RF	BW
2" / 50	49	368	368	371	190	115	132	36	27	F12	58	40
3" / 80	74	381	381	384	238	119	191	50	36	F12	83	69
4" / 100	100	457	457	460	295	148	208	58	40	F14	129	112
6" / 150	150	610	610	613	340	250	276	73	58	F16	294	254
8" / 200	201	737	737	740	435	302	327	91	75	F25	516	462
10" / 250	252	838	838	841	500	376	362	91	75	F25	720	560
12" / 300	303	965	965	968	590	424	428	110	98	F30	1135	915
14" / 350	324	1029	1029	1038	640	431	454	120	98	F30	1420	1102
16" / 400	373	1130	1130	1140	730	487	502	120	98	F30	1863	1358
18" / 450	425	1219	1219	1232	808	524	509	130	98	F30	2850	2394
20" / 500	473	1321	1321	1334	889	565	539	150	125	F35	3780	3162
24" / 600	572	1549	1549	1568	1069	670	644	221	150	F40	5682	4671
28" / 700	665	1660	1600	1695	1310	825	784	200	150	F40	*	*
30" / 750	712	1880	1660	1902	1390	865	835	220	*	*	*	*
32" / 800	760	1850	1760	1885	1475	910	895	220	*	*	*	*
34" / 850	808	1950	1850	1992	1540	940	930	250	*	*	*	*
36" / 900	855	2286	1950	2315	1600	970	960	275	*	*	*	*
40" / 1000	956	1850	2000	-	1620	960	930	245	*	*	*	*
42" / 1050	1006	1900	2100	-	1690	965	1012	260	*	*	*	*
48" / 1200	1149	2400	2200	-	*	*	*	*	*	*	*	*
56" / 1400	1342	2540	2350	-	*	*	*	*	*	*	*	*

\*These dimensions will be sent on request.

## Class 1500 • PN 250

NPS / DN	Dimensions [mm]									ISO 5211	° kg	
	øD	L <sub>RF</sub>	L <sub>BW</sub>	L <sub>RTJ</sub>	øA	B	C	E	ød <sub>7</sub>		RF	BW
2" / 50	49	368	368	371	190	115	134	36	27	F12	58	40
3" / 80	74	470	470	473	252	126	198	64	48	F14	115	88
4" / 100	100	546	546	549	295	140	208	58	40	F16	171	152
6" / 150	144	705	705	711	372	280	265	73	58	F16	407	330
8" / 200	194	832	832	841	536	388	350	96	75	F25	735	615
10" / 250	241	991	991	1000	652	446	427	96	75	F25	1120	925
12" / 300	289	1130	1130	1146	766	503	470	110	98	F30	1550	1300
14" / 350	318	1257	1257	1276	868	569	522	110	98	F30	1915	1600
16" / 400	362	1384	1384	1407	790	507	522	187	130	F35	3225	2650
18" / 450	407	1537	1537	1559	1090	680	650	185	125	F35	4300	3550
20" / 500	454	1664	1664	1686	1180	725	692	185	125	F35	5455	4515
24" / 600	546	1943	1943	1972	1415	858	817	260	170	F40	7860	6540

## Class 2500 • PN 420

NPS / DN	Dimensions [mm]									ISO 5211	° kg	
	øD	L <sub>RF</sub>	L <sub>BW</sub>	L <sub>RTJ</sub>	øA	B	C	E	ød <sub>7</sub>		RF	BW
2" / 50	42	451	451	454	230	175	182	50	40	F14	112	75
3" / 80	62	578	578	584	275	200	215	61	48	F16	212	135
4" / 100	87	673	673	683	315	215	250	76	58	F16	270	155
6" / 150	131	914	914	927	425	360	310	98	75	F25	755	505
8" / 200	179	1022	1022	1038	545	410	375	120	98	F30	1415	1110
10" / 250	223	1270	1270	1292	630	455	432	125	98	F30	2190	1510
12" / 300	265	1422	1422	1445	750	420	525	150	125	F35	3000	2020
14" / 350	292	-	1480	1630	805	600	575	160	130	F40	3700	3290
16" / 400	333	-	1540	1815	900	630	625	190	150	F40	560	4050

°Weights are informative only because of potential technological deviations.



## Seat construction

Fig.	Type of seat	Description	Fluid	Temperature of the working medium	Working pressure	Material of seat insert	Seals
3a	Seat PMSS with elastomer and thermoplastic	Metallic contact between the seat and the ball guarantees protection of secondary seals that are made of thermoplastics and elastomers.	Gases with defined content of mechanical impurities.	* from -46°C to 220°C	class 150-900 (PN 16-160), up to class 1500 (PN 250) only to NPS 6 (DN 150)	POM, PEEK, HNBR, VITON	HNBR, VITON
3b	Seat with thermoplastic	Metallic contact between the seat and the ball provides protection of thermoplastic.	Liquids and gases with defined content of mechanical impurities.	* from -60°C to 220°C	class 150-2500 (PN 16-420)	RPTFE, PEEK	HNBR, VITON
3c	Metal-to-metal seated seat	Seating surfaces of the seat and the ball are sprayed with hard metal. The surfaces are lapped together to achieve the required tightness.	Contaminated gases and liquids, mixtures of solids and liquids.	* from -46°C to 220°C	class 150-1500 (PN 16-250)	metal+TCC – metal+TCC	HNBR, VITON, GRAFIT
3d	Cryogenic seat	Tightness is provided by a seat insert made of RPTFE or PCTFE (KEL-F) thermoplastic.	Liquefied gaseous substances.	* from -46°C to -196°C	class 150-1500 (PN 16-160)	RPTFE (do -100°C), PCTFE (do -196°C)	LIP-SEAL
	**Special seats	Depending on the fluid and the service parameters, also special designs of seats are available.	Steam, sea water, chemical compounds, etc.	acc. to request	acc. to request	Elastomers and thermoplastics of various types (NYLON, DEVLON).	Elastomers of other types, graphite boxes.

\*Temperature range of the ball valve depends on the material of the seat insert and the material of seals. For temperature of the working medium above 200 °C is the limit value of pressure related to the quality of the material of body acc. to ANSI B16.34 or EN 1092-1

\*\*The design of the special seat is always a part of the drawing documentation submitted with the quotation.

