



Application

Double-eccentric butterfly valves are industrial valves, which are designed to fully open or close the passage of the working medium flowing through a pipeline. They can also be used for flow-control purposes. However, a 100% tightness of the valve cannot be guaranteed in a long-term use for control purposes.

Working medium

- waste and service water
- drinking water
- hot water
- steam
- non-aggressive liquids and gases
(natural gas, CO-gas, petroleum products, etc.)

Butterfly valve is possible to deliver with surface protection which is done by coverage with plastic material (rilsan, halar). This surface protection together with the use of stainless steel material is widening the usage of butterfly valves for chemically aggressive or abrasive media and sea water.

Maximum working temperature

A maximum working temperature of the butterfly valve depends on the packing material used.

Technical description

Double eccentricity (Fig. A)

1. the operating shaft axis is eccentric to the packing axis of the disc
2. the operating shaft axis is eccentric to the flow axe

Disc is clamped on the operating shaft and pivot, which are pivoted in self-lubricated friction bearings (Fig. B).

The shaft is sealed by gland packing (Fig. B).

The pivot is sealed by flat gasket.

The gasket bears on the conical area of the stainless steel seat, and is together with the disc pushed by the media pressure onto the conical seat, and by this is an absolute tightness reached (Fig. C). The tightness is restricted when the media flow is from the opposite side. To see the tightness grade is upon request.

For DN 80-125 is the major packing ring attached in the body by the thrust ring. In the „closed“ position, the disc is pushed against the seat by its conical area due to the pressure caused by the working medium, which ensures a total tightness in that direction (Fig. D). For all the valve variants, however, the valve tightness is limited in the opposite flow direction. For the leakage class in opposite direction please contact manufacturer.

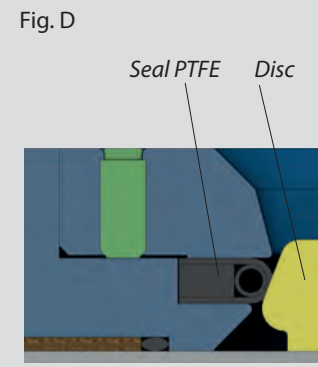
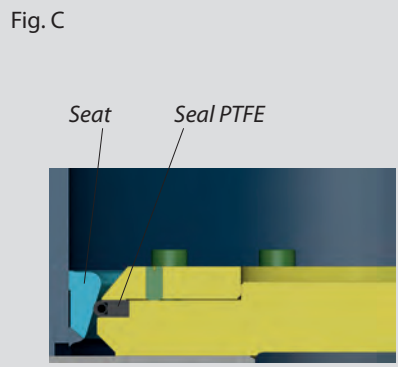
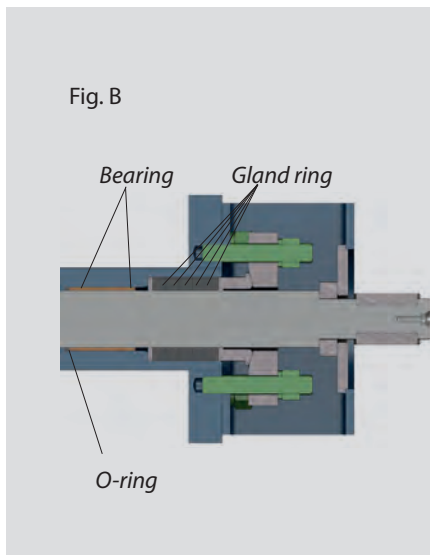
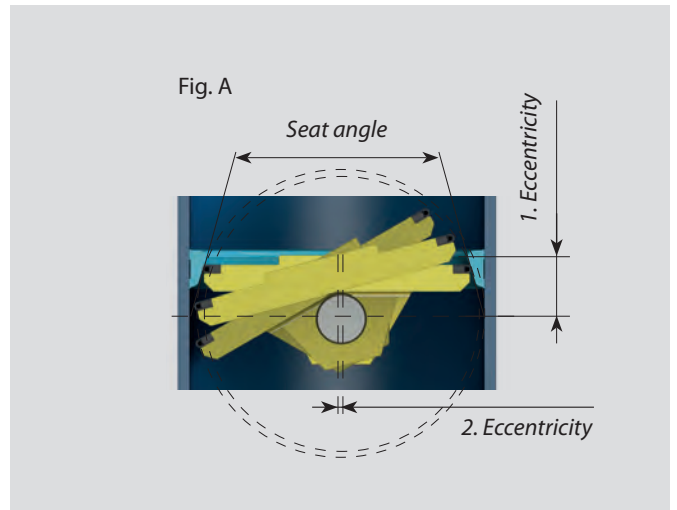
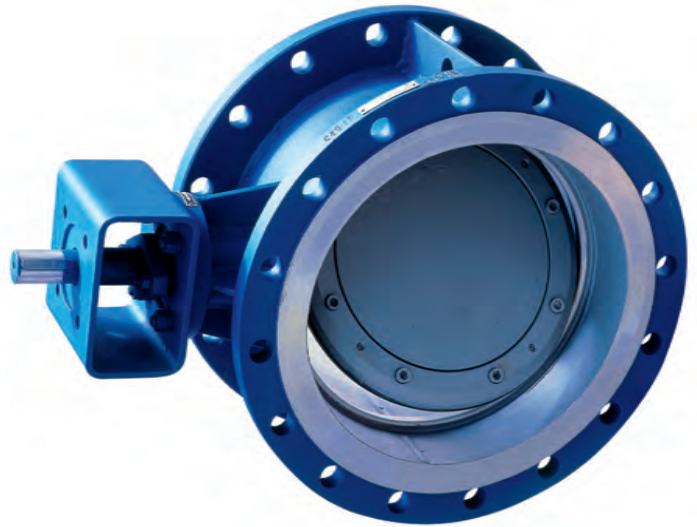

Operation

- manual gear-box
- electric actuator
- pneumatic or hydraulic actuator
- remote control from stand
- lever with a counterweight for closing the valve
- hydraulic cylinder for opening the valve

Testing

The valves are tested according to EN 12 266-1/ISO 5208.

Connection to piping

- **flanged ends** acc. to EN 1092-1, face to face dimensions acc. to EN 558-1, Series 14
- **wafer type** acc. to EN 1092-1, face to face dimensions acc. to EN 558-1, Series 16
- **welded ends** acc. to EN 12 627, eventually acc. to the customer's requirement, face to face dimension acc. to EN 12 982, Series 14

Other face to face and connecting dimensions are acc. to the customer's requirement, e.g. ANSI, GOST.

Installation

The butterfly valves can be mounted into horizontal, vertical or inclined pipeline so that the arrow stamped on the valve body corresponds with the direction of the tightness (arrow points from higher pressure to lower when the disc is closed), and the rotating axe of the disc is in a horizontal position. The bolt type at the pivot area is also very important. When there is a butterfly valve with electric actuator it is important to abide the actuator's manufacturer.

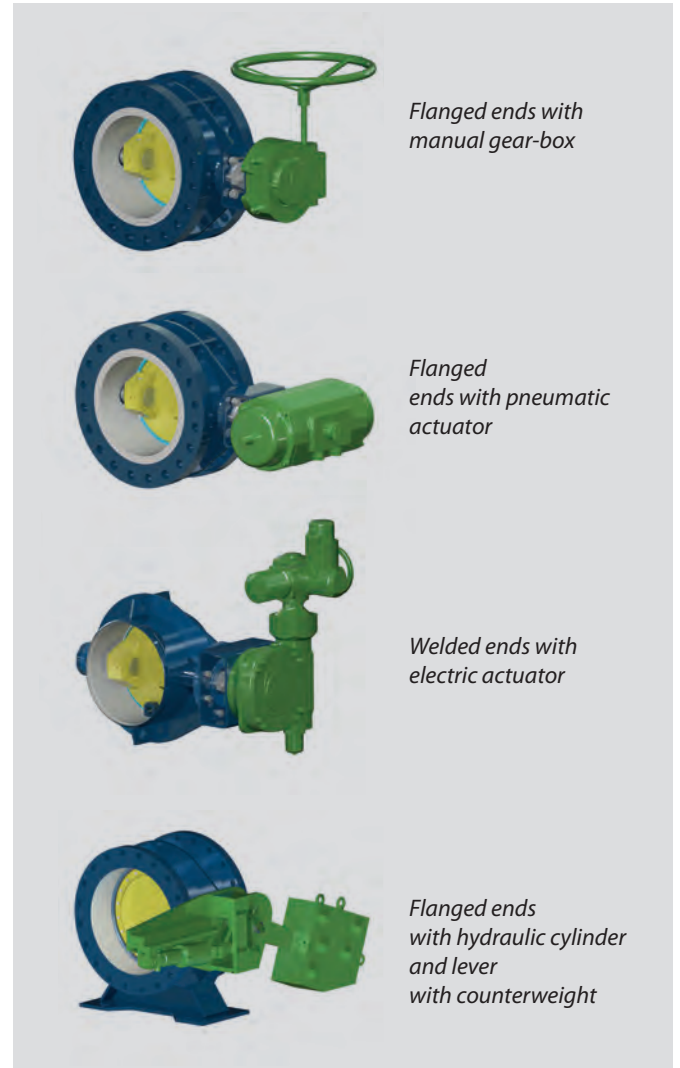

Production range

DN	Flanged ends						Welded ends						Wafer type					
	PN						PN						PN					
	2,5	6	10	16	25	40	2,5	6	10	16	25	40	2,5	6	10	16	25	40
80														*	*	*	*	*
100														*	*	*	*	*
125														*	*	*	*	*
150		*	*	*	*	*		*	*	*	*	*		*	*	*	*	*
200		*	*	*	*	*		*	*	*	*	*		*	*	*	*	*
250		*	*	*	*	*		*	*	*	*	*		*	*	*	*	*
300		*	*	*	*	*		*	*	*	*	*		*	*	*	*	*
350		*	*	*	*	*		*	*	*	*	*		*	*	*	*	*
400		*	*	*	*	*		*	*	*	*	*		*	*	*	*	*
500		*	*	*	*	*		*	*	*	*	*		*	*	*	*	*
600		*	*	*	*	*		*	*	*	*	*		*	*	*	*	*
700		*	*	*	*	*		*	*	*	*	*		*	*	*	*	*
800		*	*	*	*	*		*	*	*	*	*		*	*	*	*	*
1000		*	*	*	*	*		*	*	*	*	*		*	*	*	*	*
1200	*	*	*	*	*	*		*	*	*	*	*		*	*	*	*	*
1400	*	*	*	*	*	*		*	*	*	*	*		*	*	*	*	*
1600	*	*	*	*	*	*		*	*	*	*	*		*	*	*	*	*
2000	*	*	*	*	*	*		*	*	*	*	*		*	*	*	*	*

Rubber sealed butterfly valves with double-eccentricity type L32.7 are produced in the same production range as type L32.6.



DN 150-2000 • PN 2,5-40 • Tmax +250 °C
Design: PTFE seal

Connection:  EN 1092-1 FLANGED ENDS
 EN 12 627 WELDED ENDS
 EN 1092-1 WAFER TYPE

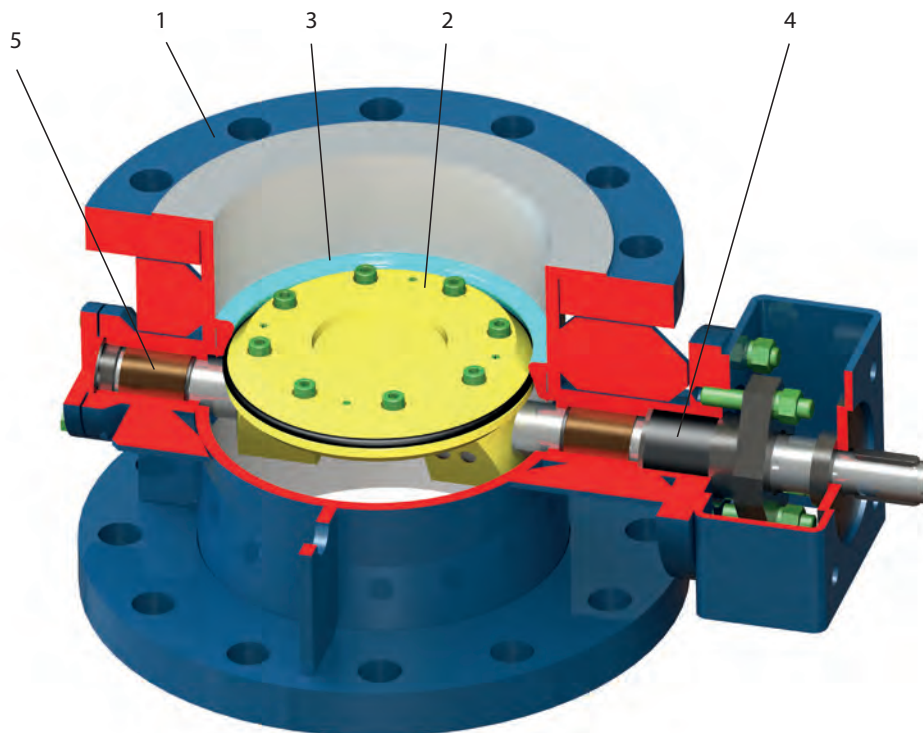

Material

Position	Component	Standard acc. to EN		EN		ASTM		
		Carbon steel		Stainless steel		Carbon steel		Stainless steel
		-29 °C - +250 °C*	-46 °C - +250 °C*	-50 °C - +250 °C*		-29 °C - +250 °C*	-46 °C - +250 °C*	-50 °C - +250 °C*
1	Body	1.0577,1.0425	1.0566	1.4541		A105	A350 LF2	A182 F316
2	Disc	1.0577,1.0425	1.0566	1.4541		A105	A350 LF2	A182 F316
3	Seat	1.4541, 1.4301		1.4541		A182 F304	A182 F304	A182 F316
4	Shaft	1.4021 + QT700	1.4021 + QT700	1.4541		A182 F6A	A182 F6A	A182 F316
5	Pivot	1.4021 + QT700	1.4021 + QT700	1.4541		A182 F6A	A182 F6A	A182 F316

* The thermal use of the valve depends on the pressure-temperature characteristic of the material - see further information in this catalog.

Recommended seal resistance

Elastomer	Identification	Identification	Working temperature
Teflon	PTFE	Wastewater and service water, seawater, hot water and steam, non-aggressive liquids and gases	from -50 °C to +250 °C
Nitrile-butadien rubber *	NBR	Water, air, engine and gear oils, petrol, mineral oils, heating gases, non-aggressive gases	from -20 °C to +80 °C
Ethylene-propylene rubber *	EPDM	Drinking water, hot water, steam, diluted acids and alkalis, air; unsuitable for oils and fats	from -40 °C to +130 °C
Fluorine rubber *	FPM	Mineral oils, petroleum products, coke and blast furnace gas, the highest chemical resistance of all elastomers (rubber); unsuitable for hot steam and water	from -20 °C to +140 °C
	VITON GF	Hot water and steam	from -20 °C to +180 °C

* Butterfly valves with rubber seal for double eccentricity type L32.7 are manufactured in the same production range as L32.6 and dimension tables are identical with type L32.6.



DN 150-2000 • PN 2,5-40 • Tmax +250 °C
Design: PTFE seal

Connection: EN 1092-1 FLANGED ENDS
 EN 12 627 WELDED ENDS

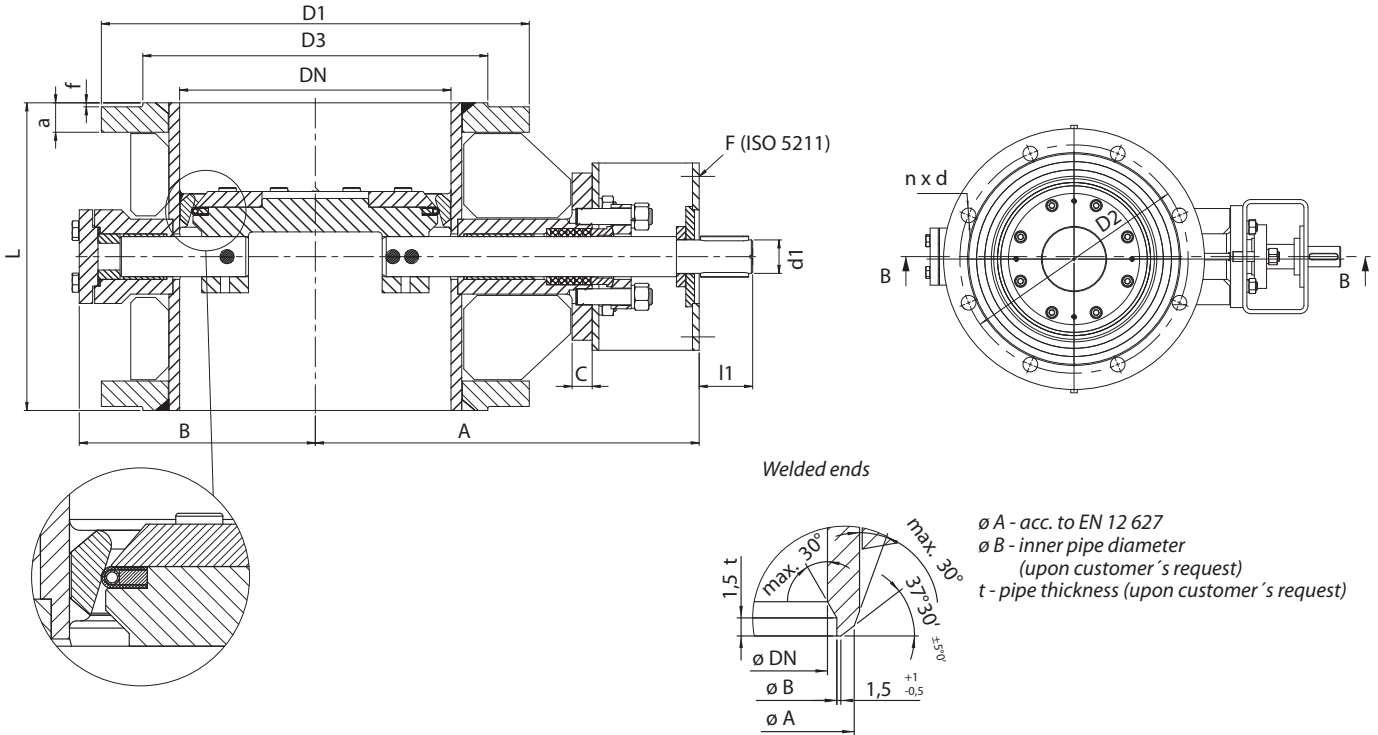

PN 2,5

DN	A	B	C	L*	F	d1	l1	Flanged ends							
								D1	D2	D3	a	f	d	n	kg
1200	1180	800	30	630	25	65	110	1375	1320	1280	40	2	30	32	1250
1400	1150	890	30	710	30	80	125	1575	1520	1480	44	2	30	36	1640
1600	1270	1100	30	790	35	100	165	1790	1730	1690	48	2	30	40	2840
2000	1500	1300	35	950	40	140	200	2190	2130	2090	54	2	30	48	4680

PN 6

DN	A	B	C	L*	F	d1	l1	Flanged ends							
								D1	D2	D3	a	f	d	n	kg
150	253	146	15	210	10	25	40	265	225	202	20	2	18	8	39
200	290	180	15	230	10	25	40	320	280	258	22	2	18	8	45
250	320	210	20	250	12	30	50	375	335	312	24	2	18	12	54
300	335	230	20	270	12	30	50	440	395	365	24	2	22	12	82
350	360	260	20	290	12	35	50	490	445	415	26	2	22	12	118
400	400	295	20	310	12	35	50	540	495	465	28	2	22	16	164
500	510	360	25	350	14	40	60	645	600	570	30	2	22	20	240
600	560	415	25	390	16	50	80	755	705	670	30	2	26	20	370
700	600	460	25	430	16	50	80	860	810	775	32	2	26	24	520
800	770	530	25	470	25	60	95	975	920	880	34	2	30	24	710
1000	830	660	30	550	30	80	110	1175	1120	1080	36	2	30	28	1090
1200	1030	800	30	630	30	80	123	1405	1340	1295	40	2	33	32	1310
1400	1150	890	30	710	35	100	165	1630	1560	1510	44	2	36	36	1700
1600	1300	1100	35	790	40	140	200	1830	1760	1710	48	2	36	40	3100
2000	1500	1300	35	950	48	160	250	2265	2180	2125	54	2	42	48	4800

* face to face dimensions for welded ends are in compliance with flange connections (can be different upon customer's request)

Pipe dimensions $\varnothing D \times t$ ($\varnothing D$ – outside pipe diameter; t – the pipe thickness) for welding are given by customer.



DN 150-2000 • PN 2,5-40 • Tmax +250 °C
Design: PTFE seal

Connection:  EN 1092-1 FLANGED ENDS
 EN 12 627 WELDED ENDS

PN 10

DN	A	B	C	L*	F	d1	l1	Flanged ends							
								D1	D2	D3	a	f	d	n	kg
150	253	146	15	210	10	25	40	285	240	212	24	2	22	8	40
200	290	180	15	230	10	25	40	340	295	268	24	2	22	8	45
250	320	210	20	250	12	30	50	395	350	320	26	2	22	12	60
300	335	230	20	270	12	30	50	445	400	370	26	2	22	12	80
350	360	260	20	290	12	35	50	505	460	430	28	2	22	16	100
400	400	295	20	310	14	40	60	565	515	482	32	2	26	16	140
500	510	360	25	350	16	50	80	670	620	585	38	2	26	20	235
600	560	415	25	390	25	60	95	780	725	685	42	2	30	20	365
700	620	485	25	430	25	65	110	895	840	800	42	2	30	24	505
800	700	550	25	470	25	70	110	1015	950	905	44	2	33	24	700
1000	850	680	30	550	30	80	125	1230	1160	1110	44	2	36	28	1090
1200	940	760	30	630	35	100	165	1455	1380	1330	46	2	39	32	1280
1400	1280	980	40	710	40	140	200	1675	1590	1535	48	2	42	36	2790
1600	1620	1080	40	790	48	160	200	1915	1820	1760	58	2	48	40	3690
2000	1820	1350	40	950	60	178	310	2325	2230	2170	64	2	48	48	3990

PN 16

DN	A	B	C	L*	F	d1	l1	Flanged ends							
								D1	D2	D3	a	f	d	n	kg
150	253	146	15	210	10	25	40	285	240	212	24	2	22	8	46
200	265	175	15	230	10	25	40	340	295	268	26	2	22	12	46
250	315	205	20	250	12	30	50	405	355	320	29	2	26	12	62
300	350	245	20	270	12	35	50	460	410	378	32	2	26	12	95
350	380	275	20	290	14	40	60	520	470	438	35	2	26	16	127
400	455	310	25	310	16	50	80	580	525	490	38	2	30	16	174
500	520	375	25	350	16	50	80	715	650	610	46	2	33	20	255
600	620	435	30	390	25	60	95	840	770	725	52	2	36	20	392
700	670	490	30	430	30	70	110	910	840	795	52	2	36	24	550
800	750	565	30	470	30	80	125	1025	950	900	54	2	39	24	745
1000	865	700	30	550	35	100	165	1255	1170	1115	54	2	42	28	1260
1200	1000	810	35	630	40	120	180	1485	1390	1330	58	2	48	32	1700
1400	1280	980	40	710	48	160	200	1685	1590	1530	58	2	48	36	2890
1600	1620	1080	40	790	60	178	310	1930	1820	1750	64	2	56	40	3275

PN 25

DN	A	B	C	L*	F	d1	l1	Flanged ends							
								D1	D2	D3	a	f	d	n	kg
150	253	146	15	210	10	25	40	300	250	218	30	2	26	8	53
200	290	185	20	230	12	30	50	360	310	278	32	2	26	12	55
250	325	225	20	250	14	35	50	425	370	335	35	2	30	12	71
300	350	250	20	270	14	40	60	485	430	395	38	2	30	16	109
350	440	295	25	290	16	50	80	555	490	450	42	2	33	16	155
400	475	330	25	310	16	50	80	620	550	505	46	2	36	16	208
500	535	395	30	350	25	60	95	730	660	615	56	2	36	20	298
600	660	460	30	390	30	70	110	845	770	720	68	2	39	20	525
700	690	505	30	430	30	80	125	960	875	820	68	2	42	24	640
800	805	580	30	470	35	100	130	1085	990	930	70	2	48	24	860
1000	1000	800	35	550	40	120	180	1320	1210	1140	70	2	56	28	1500
1200	1150	910	40	630	48	140	200	1550	1420	1350	70	2	56	32	2290
1400	1280	980	40	710	60	178	310	1755	1640	1560	76	2	62	36	3690

* face to face dimensions for welded ends are in compliance with flange connections (can be different upon customer's request)

Pipe dimensions $\varnothing D \times t$ ($\varnothing D$ – outside pipe diameter; t – the pipe thickness) for welding are given by customer.



DN 150-2000 • PN 2,5-40 • Tmax +250 °C
Design: PTFE seal

Connection: ☉ EN 1092-1 FLANGED ENDS
☼ EN 12 627 WELDED ENDS

PN 40

DN	A	B	C	L*	F	d1	l1	Flanged ends							
								D1	D2	D3	a	f	d	n	kg
150	200	150	20	210	12	27	45	300	250	218	28	2	26	8	87
200	230	205	25	230	12	35	50	375	320	285	34	2	30	12	102
250	270	255	25	250	14	40	60	450	385	345	38	2	33	12	133
300	305	280	25	270	16	50	80	515	450	410	42	2	33	16	205
350	355	315	25	290	16	50	80	580	510	465	46	2	36	16	275
400	380	340	30	310	25	60	95	660	585	535	50	2	39	16	400
500	450	425	30	350	30	70	110	755	670	615	57	2	42	20	530
600	535	510	35	390	35	85	130	890	795	735	72	2	48	20	940
700	580	550	35	430	35	100	165	995	900	840	76	2	48	24	1150
800	715	670	35	470	40	120	180	1140	1030	960	79	2	56	24	1550

* face to face dimensions for welded ends are in compliance with flange connections (can be different upon customer's request)

Pipe dimensions $\varnothing D \times t$ ($\varnothing D$ – outside pipe diameter; t – the pipe thickness) for welding are given by customer.



Butterfly valve L32.7 DN 3500 - install in the hydropower plant in Rendalen in Norway.



DN 80-2000 • PN 2,5-40 • Tmax +250 °C
Design: PTFE seal

Connection:  EN 1092-1 WAFER TYPE

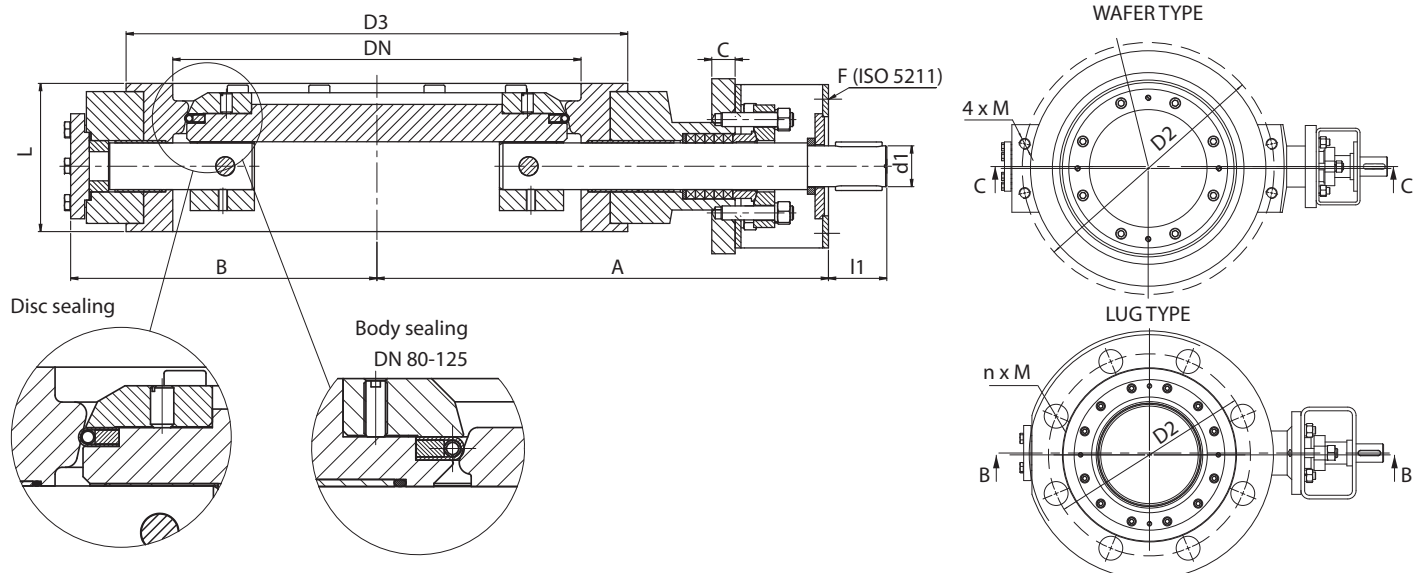

PN 2,5

DN	A	B	C	L	F	D2	D3	d1	n	M	l1	kg
1200	1210	800	30	350	25	1320	1280	65	32	M27	110	1050
1400	1180	890	30	390	30	1520	1480	65	36	M27	110	1400
1600	1300	1100	35	440	35	1730	1690	100	40	M27	145	2500
2000	1530	1300	35	540	40	2130	2090	140	48	M27	165	4200

PN 6

DN	A	B	C	L	F	D2	D3	d1	n	M	l1	kg
80	190	105	-	64	07	160	138	16	4	M16	30	16
100	200	115	-	64	07	180	158	16	4	M16	30	18
125	235	140	-	70	07	210	188	20	8	M16	30	22
150	253	146	15	76	10	225	202	25	8	-	40	53
200	290	200	15	89	10	280	258	25	8	-	40	60
250	320	210	20	114	12	335	312	30	12	M16	50	64
300	335	230	20	114	12	395	365	30	12	M20	50	70
350	360	260	20	127	12	445	415	35	12	M20	50	89
400	400	295	20	140	12	495	465	35	16	M20	50	110
500	495	355	25	152	14	600	570	40	20	M20	60	195
600	550	410	25	178	16	705	670	50	20	M24	80	280
700	600	460	25	229	16	810	775	50	24	M24	80	390
800	770	530	25	241	25	920	880	60	24	M27	95	550
1000	830	660	30	300	30	1120	1080	80	28	M27	110	820
1200	920	750	30	350	30	1340	1295	80	32	M30	125	1240
1400	1180	890	30	390	35	1560	1510	100	36	M33	165	2600
1600	1300	1100	35	440	40	1760	1710	140	40	M33	200	2800
2000	1530	1300	50	540	48	2180	2125	160	48	M39	250	4350

* these apply only for lug type connection

Depth of the thread ("M") in the body is corresponds to the thread dimension.



DN 80-2000 • PN 2,5-40 • Tmax +250 °C
Design: PTFE seal

Connection:  EN 1092-1 WAFER TYPE

PN 10

DN	A	B	C	L	F	D2	D3	d1	n	M	l1	kg
80	190	105	-	64	07	160	138	16	8	M16	30	16
100	200	115	-	64	07	180	158	16	8	M16	30	18
125	235	140	-	70	07	210	188	16	8	M16	30	22
150	253	146	15	76	10	240	212	25	8	-	40	50
200	290	200	15	89	10	295	268	25	8	-	40	60
250	320	210	20	114	12	350	320	30	12	M20	50	64
300	335	230	20	114	12	400	370	30	12	M20	50	68
350	360	260	20	127	12	460	430	35	16	M20	50	92
400	400	295	20	140	14	515	482	40	16	M24	60	115
500	495	355	25	152	16	620	585	50	20	M24	80	200
600	550	410	25	178	25	725	685	60	20	M27	95	290
700	620	485	25	229	25	840	800	65	24	M27	110	415
800	700	550	25	241	25	950	905	70	24	M30	110	640
1000	850	680	30	300	30	1160	1110	80	28	M33	125	835
1200	940	760	30	350	35	1380	1330	100	32	M36	165	1260
1400	1300	980	40	390	40	1590	1535	140	36	M39	200	2600
1600	1670	1080	40	440	48	1820	1760	160	40	M45	200	2800
2000	1850	1350	40	540	60	2230	2170	178	48	M45	310	4400

PN 16

DN	A	B	C	L	F	D2	D3	d1	n	M	l1	kg
80	190	105	-	64	07	160	138	16	8	M16	30	16
100	200	115	-	64	07	180	158	16	8	M16	30	18
125	235	140	-	70	07	210	188	20	8	M16	30	22
150	253	150	15	76	10	240	212	25	8	-	40	50
200	280	190	15	89	10	295	268	25	12	M20	40	60
250	320	225	20	114	12	355	320	30	12	M24	50	64
300	335	260	20	114	12	410	378	35	16	M24	50	72
350	360	295	20	127	14	470	438	40	16	M24	60	95
400	455	320	25	140	16	525	490	50	20	M27	80	120
500	495	390	25	152	16	650	610	50	20	M30	80	215
600	615	460	30	178	25	770	725	60	24	M33	95	310
700	640	505	30	229	30	840	795	70	24	M33	110	435
800	750	580	30	241	30	950	900	80	28	M36	125	600
1000	860	800	30	300	35	1170	1115	100	32	M39	165	1100
1200	980	890	35	350	40	1390	1330	120	36	M45	180	1325
1400	1300	980	40	390	48	1590	1530	160	40	M45	200	2900
1600	1700	1080	40	440	60	1820	1750	178	48	M52	310	3275

* these apply only for lug type connection

Depth of the thread ("M") in the body is corresponds to the thread dimension.



DN 80-2000 • PN 2,5-40 • Tmax +250 °C
Design: PTFE seal

Connection:  EN 1092-1 WAFER TYPE

PN 25

DN	A	B	C	L	F	D2	D3	d1	n	M	l1	kg
80	195	110	-	64	07	160	138	16	8	M16	30	17
100	210	120	-	64	07	190	162	20	8	M20	30	19
125	240	145	-	70	10	220	188	25	8	M24	40	25
150	253	150	15	76	10	250	218	25	8	-	50	55
200	290	190	20	89	12	310	278	30	12	M24	50	60
250	325	225	20	114	14	370	335	35	12	M27	50	65
300	370	260	20	114	14	430	395	40	16	M27	60	85
350	445	295	25	127	16	490	450	50	16	M30	80	115
400	510	330	25	140	16	550	505	50	16	M33	80	170
500	565	395	30	152	25	660	615	60	20	M33	95	260
600	630	460	30	178	30	770	720	70	20	M36	110	380
700	690	505	30	229	30	875	820	80	24	M39	125	610
800	805	580	30	241	35	990	930	100	24	M45	130	770
1000	980	800	35	300	40	1210	1140	120	28	M52	180	1390
1200	1170	910	40	350	48	1420	1350	140	32	M52	200	1500
1400	1300	980	40	390	60	1640	1560	178	36	M56	310	3100

PN 40

DN	A	B	C	L	F	D2	D3	d1	n	M	l1	kg
80	195	110	-	64	07	160	138	20	8	M16	30	17
100	210	120	-	64	07	190	162	20	8	M20	30	19
125	240	145	-	70	10	220	188	25	8	M24	40	25
150	250	150	20	76	12	250	218	27	8	-	45	58
200	250	205	25	89	12	320	285	35	12	M27	50	66
250	290	255	25	114	14	385	345	40	12	M30	60	74
300	320	280	25	114	16	450	410	50	16	M30	80	97
350	380	315	25	127	16	510	465	50	16	M33	80	130
400	410	340	30	140	25	585	535	60	16	M36	95	190
500	470	425	30	152	30	670	615	70	20	M39	110	280
600	550	510	35	178	35	795	735	85	20	M45	130	430
700	600	550	35	229	35	900	840	100	24	M45	165	690
800	720	670	35	241	40	1030	960	120	24	M52	180	860

* these apply only for lug type connection

Depth of the thread ("M") in the body is corresponds to the thread dimension.

